

APPLICATION AND USE

2F.. series valves are used to control fluids belonging to the group showed in the table according to article 9 of 97/23/CE directive (PED) in air-conditioning, thermoventilation and heating plants and in industrial processes; therefore, they cannot be employed as safety valves.

MANUFACTURING CHARACTERISTICS

They consist in a two-way simple seat valve body to be assembled on an electrical bidirectional actuator.

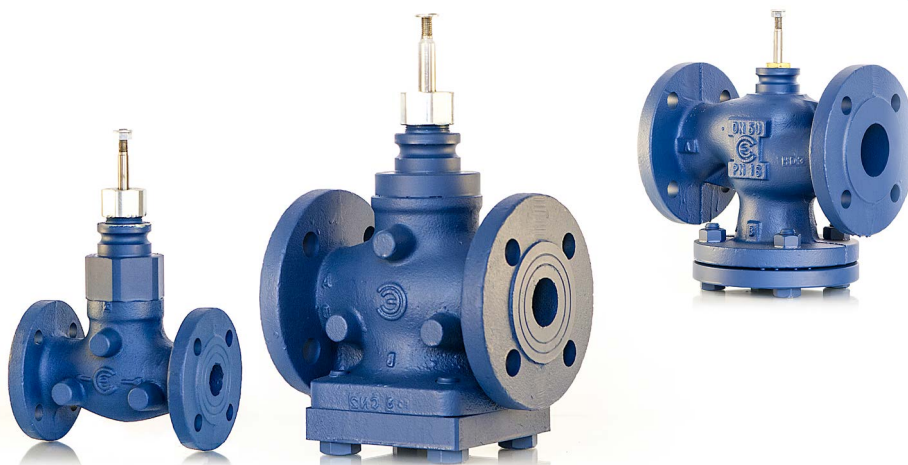

Technical data	Model	2FGB DN25÷150	2FGA DN15÷100	2FSA DN25÷65	2FAA DN15÷80	2FAA.P DN15÷80	2FAA.T DN15÷80
Construction		PN16	PN16	PN25	PN40	PN40	PN40
Body		flake cast iron	hydraulic cast iron	spheroidal cast iron	steel	steel	steel
Seat		flake cast iron	stainless steel	steel	stainless steel	stainless steel	stainless steel
Plug		brass	stainless steel	steel	stainless steel	stainless steel	stainless steel
Stem (Ø 9mm)		stainless steel	stainless steel	stainless steel	stainless steel	stainless steel	stainless steel
Control characteristics		equalpercentage	equalpercentage	equipercantage	equipercantage	equipercantage	equipercantage
Stem packing		EPDM O-ring ⁽⁴⁾	Teflon V-ring	Teflon V-ring	Teflon V-ring	(2)	(2)
Max. fluid temperature °C		150	200	230	230	350	230
Min. fluid temperature °C		-10 ⁽¹⁾	-10 ⁽¹⁾	-10 ⁽¹⁾	-10 ⁽¹⁾	-10 ⁽¹⁾	-20 ⁽¹⁾
Fluid ⁽⁴⁾		Group 2	Group 2	Group 2	Group 2	Group 1	Group 1
Connections		Flanged PN16	Flanged PN16	Flanged PN25	Flanged PN40	Flanged PN40	Flanged PN40
Leakage % Kvs ⁽⁵⁾		0,03	0,02	0,02	0,02	0,02	0,02
Lowered stem action		normally open	normally closed	normally open	normally closed	normally closed	normally closed

(1) For applications with possible ice formation on stem and gasket, see 248 accessory.

(2) Graphite packing for high temp.; forced lubrication on extended neck. Teflon gasket for low temperatures, see (3).

(4) Double O-ring and graphited teflon scraper ring.

5) Group 1: just diathermic oil. For different fluids, please contact our Sales Support.

Group 2: water, overheated water, glycol added water 50% max., steam. For different fluids, please contact our Sales Support.

(6) Leakage is measured according to the EN1349 standard.

MOTORIZED VALVES OPTIONS

A125-2 flanges with ANSI 125 bolt holes (for 2FGA DN25,32,50,65 and 2FGB DN25÷150 valves)

A150-2 flanges with ANSI 150 bolt holes (for 2FAA DN32÷65 and 2FSA DN50÷65 valves)

A300-2 flanges with ANSI 300 bolt holes (for 2FSA DN25÷65 and 2FAA DN15,32,40,50,65 valves)

PS89 grooved valves to which it is possible to add the relating joint not supplied with the product. General dimensions remain the same. Joint and pipe dimensions are shown in the "Dimensions" paragraph.

ACCESSORIES

248 stem heater for applications on -10°C low temperature fluid with MVH and MVE actuators

GVB40 thermal insulation for DN40 for 2FGB40 valves;
GVB50 thermal insulation for DN50 for 2FGB50 valves;
GVB65 thermal insulation for DN65 for 2FGB65 valves;
GVB80 thermal insulation for DN80 for 2FGB80 valves;
GVB100 guscio protettivo per valvole DN100 per 2FGB100;
GVB125 guscio protettivo per valvole DN125 per 2FGB125;
GVB150 guscio protettivo per valvole DN150 per 2FGB150.

See actuators data sheets and mounting instructions. Kvs is the flow rate in m³/h of water at a temperature between 5°C and 40°C passing through a valve open at nominal stroke with 100kPa (1bar) differential pressure.

MAX DIFFERENTIAL AND CLOSE-OFF PRESSURE [kPa]

			MVH	MVHA/C*	MVH3K	MVE.06	MVE.10	MVE.15
U-Bolt Connection	DN	Kvs	A-AB	A-AB	A-AB	A-AB	A-AB	A-AB
2FGA	15R0	0,6	1600	1600	1600	1600	1600	1600
	15R1	1						
	15R2	1,6						
	15R3	2,5						
	15	4	1600	1600	1600	1600	1600	1600
	20	6,3	1600	1510	1600	1250	1600	1600
	25	10	1600	920	1600	760	1410	1600
	32	16	1600	920	1600	760	1410	1600
	40	24	1340	620	1600	510	950	1500
	50	40	870	400	1600	330	620	980
	65	63	350	160	830	130	250	400
	80	110	230	100	550	80	160	260
100	140	140	60	350	50	100	160	
2FAA 2FAA..P 2FAA..T	15R2	1,6	3000	3000	3000	3000	3000	4000
	15	4	3000	1870	3000	1450	3210	4000
	20	6,3	2840	1110	3000	850	1900	3220
	25	10	1740	670	3000	510	1160	1980
	32	16	1740	670	3000	510	1160	1980
	40	24	1170	450	2920	340	780	1330
	50	40	760	290	1910	220	510	870
	65	63	310	110	790	80	200	350
80	110	200	70	520	50	130	230	
2FGB	25R4	4	1600	1100	1600	940	1590	1600
	25R7	6,3	1600	1100	1600	940	1590	1600
	25	10	1600	1100	1600	940	1590	1600
	40R	19	1170	590	1600	500	860	1300
	40	25	1170	590	1600	500	860	1300
	50	40	730	360	1600	310	530	810
	65	63	430	210	960	180	310	480
	80	100	280	130	620	110	200	310
	100	130	170	80	390	70	120	190
	125	200	100	50	240	40	70	120
	150	300	70	30	160	30	50	80
2FSA	25R4	4	2500	2150	2500	1850	2500	2500
	25R7	6,3	2150	1080	2500	930	1580	2390
	25	10	2150	1080	2500	930	1580	2390
	32	16	1450	730	2500	620	1060	1610
	40	25	1040	520	2310	440	760	1160
	50	40	660	330	1470	280	480	740
	65	63	390	190	860	160	280	430
	80	110	250	120	570	100	180	280

100 kPa = 1 bar = 10 m_{H₂O}

* 2FGB-2FSA valves: in emergency MVH.A valve closed; MVH.C valve open. 2FGA-2FAA valves: in emergency MVH.A valve open; MVH.C valve closed.

Kvs is the flow rate expressed in m³/h of water at a temperature between 5°C and 40°C passing through a valve open at the nominal stroke with 100kPa (1bar) differential pressure.

MAX REGULATION DIFFERENTIAL PRESSURE [kPa]

The max regulation differential pressure, it means the pressure which can be used during the stroke, is conditioned by wear between seat and plug and by the performance guaranteed by the actuator for the evaluated valve. So we recommend not to overcome the differential pressure whose value corresponds to the minimum between the one here following (maximum admitted value not to cause wear) and the one shown in the previous table (max close-off differential pressure).

2FGB = 200kPa

2FGA = 600kPa

2FSA = 800kPa

2FAA/2FAAP/2FAAT = 1200kPa

Note: The max operating pressures at different temperatures for various PN classes must correspond to the following standards: UNI 1092-02 and UNI 12516-1.

INSTALLATION

Hydraulic connections:

Respect the fluid direction as indicated by the arrow on the valve body or, in case letters are used with inlet in A and outlet AB.

Valve mounting:

Before mounting the valve, make sure pipes are clean, free from welding slags. The pipes must be perfectly aligned with the valve body and not subjected to vibrations. For installations on plants with high temperature fluids (steam, overheated water, diathermic oil) use expansion joints to avoid the dilatation of pipes to stress the valve body. Install the valves with the actuator in vertical position for fluid temperature up to 120°C; with higher temperatures they should be mounted horizontally.

Avoid the valve installation in plants which are considered aggressive and/or corrosive for valve materials.

Please contact our Sales Support in order to define which potentially aggressive or polluting substances can be used.

We disclaim all responsibility in case of valve failure due to external fortuitous events (fire, earthquakes etc.).

Notes: The actuator can be rotated with respect to the valve body by blocking the ring nut; after such operation re-tighten the ring nut.

OVERALL DIMENSIONS [mm]

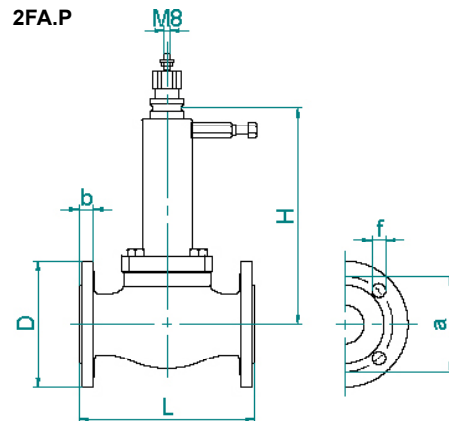
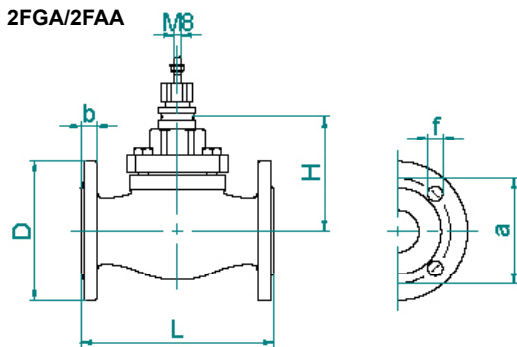
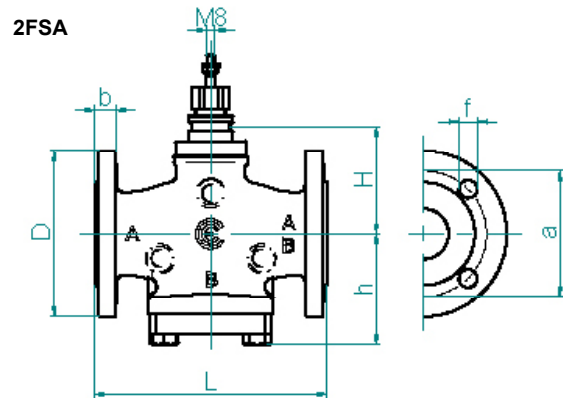
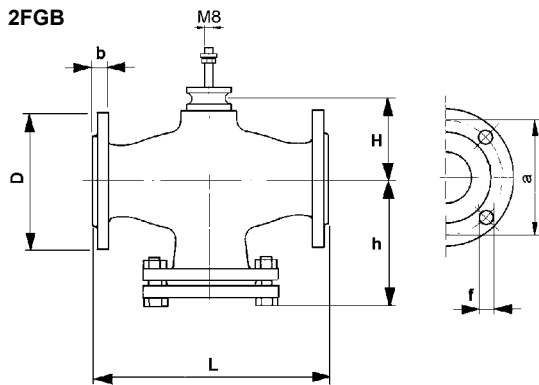

Model	DN	L	H	h	D	b	a	f	Holes nr.	Weight [kg]	Stroke [mm]
2FGB PN16	25	160	50	106	115	16	85	14	4	6,8	16,5
	40	200	64	128	150	18	110	18	4	12	25
	50	230	66	145	165	20	125	18	4	17	25
	65	290	84	175	185	20	145	18	4	23	25
	80	310	94	187	200	22	160	18	8	30	45
	100	350	105	207	220	22	180	18	8	45,6	45
	125	400	128	234	250	24	210	18	8	55	45
	150	480	146	277	285	24	240	22	8	71	45
2FGA PN16	15	130	107	--	95	16	65	14	4	3,5	16,5
	20	150	109	--	105	16	75	14	4	4,5	16,5
	25	160	112	--	115	16	85	14	4	5,5	16,5
	32	180	121	--	140	18	100	18	4	8,7	25
	40	200	129	--	150	18	110	18	4	10,3	25
	50	230	137	--	165	20	125	18	4	13,7	25
	65	270	175	--	185	20	145	18	4	19,6	25
	80	310	190	--	200	22	160	18	8	31,7	45
	100	350	215	--	220	24	180	18	8	43,5	45
2FAA PN40	15	130	107	--	95	16	65	14	4	4,1	16,5
	20	150	109	--	105	16	75	14	4	5,1	16,5
	25	160	112	--	115	16	85	14	4	6,1	16,5
	32	180	121	--	140	18	100	18	4	10,1	25
	40	200	152	--	150	18	110	18	4	12,3	25
	50	230	160	--	165	20	125	18	4	17	25
	65	270	175	--	185	20	145	18	8	23,8	25
	80	310	190	--	200	22	160	18	8	32	45
2FSA PN25	25	160	92	83	115	18	85	14	4	6	16,5
	32	180	97	102	140	18	100	18	4	10	25
	40	200	98	104	150	18	110	18	4	11	25
	50	230	107	110	165	20	125	18	4	16	25
	65	270	117	124	185	22	145	18	8	20	25
2FAAP 2FAAT PN40	15	130	178	--	95	16	65	14	4	6,2	16,5
	20	150	180	--	105	18	75	14	4	8,3	16,5
	25	160	183	--	115	18	85	14	4	8,6	16,5
	32	180	269	--	140	18	100	18	4	14,7	25
	40	200	277	--	150	18	110	18	4	15,4	25
	50	230	285	--	165	20	125	18	4	25	25
	65	270	300	--	185	22	145	18	8	29	25
	80	310	315	--	200	24	160	18	8	38	45

PS89 models

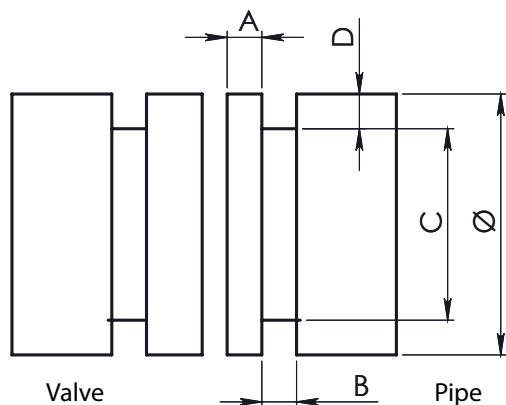

valve DN	grooved joint DN	Ø			A	B	C		D
		external pipe diameter			gasket seat	groove width	groove diameter		groove depth (ref.)
		base	max.	min.	± 0.76 ± 0.03	± 0.76 ± 0.03	max.	min.	
40	50	60,30	60,90	59,70	15,88	7,95	57,20	56,80	1,6
50	76,1	76,10	77	75,40	15,88	7,95	72,30	71,80	1,98
65	80	88,90	89,80	88,10	15,88	7,95	84,90	84,50	1,98
80	100	114,30	115,40	113,50	15,88	9,53	110,10	109,60	2,11
100	139,7	139,70	141,10	138,90	15,88	9,53	135,50	135	2,11
125	150	168,30	169,90	167,50	15,88	9,53	164	163,40	2,16

The performances stated in this sheet can be modified without any prior notice